

# MODEL 39 NON-MODULATING FLOAT PILOT WITH VERTICAL ROD

## PRODUCT OVERVIEW

The 39 non-modulating float pilot is designed to operate an On-Off float valve. The differential between the level where the valve opens and the level where the valve closes, is adjustable. The standard configuration is for the pilot valve to close on high level and open at a low level.

The 39 pilot is used as the main standard pilot on all non-modulating F-Type 5, 106 and 206 series float valves.

## ORDERING INSTRUCTIONS

Refer to page 244 for the order form and ordering instructions.

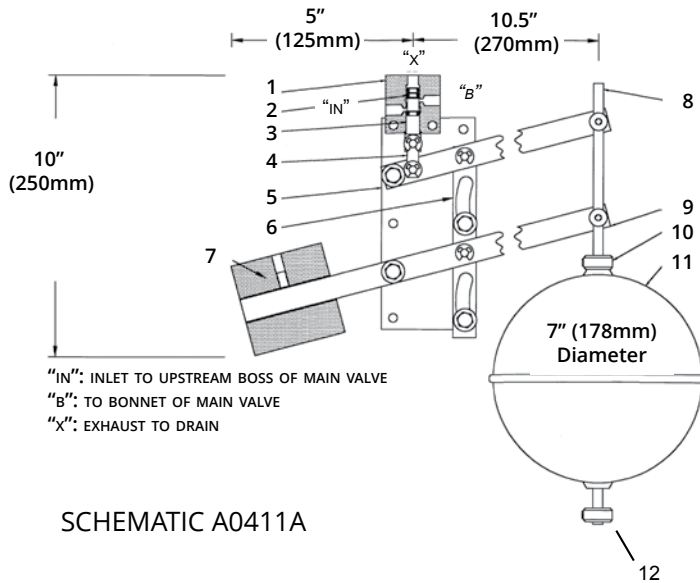
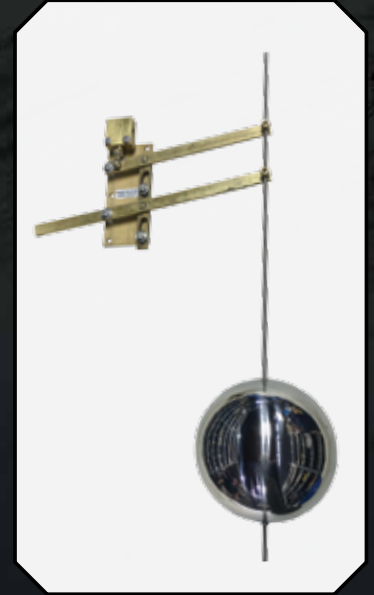

1. Body (Brass)
2. Inner Valve O-rings (Buna-N)
3. Inner Valve (Brass)
4. Connector Bar
5. Mounting Bracket (Brass)
6. Guide Bar (Brass)
7. Counter Weight (Cast Iron - Epoxy Coating)
8. Float Rod (Brass)
9. Lever Arm (Brass)
10. Adjustable Stop (Brass)
11. Float (Copper)
12. Adjustable Stop Opening (Brass)

**Options:** Available in Stainless Steel construction.